AS THE WOOD TURNS

May 2004

Wally Demonstrated Bow Ties



One tie



Two ties



When you get carried away!

Also known as a butterfly key or inlay. Used by George Nakashima for functional and decorative effect. Used by Wally to save a cracked turning and add an artistic inlay to raise the price of the piece.



An acrylic template is fastened over the crack in bowl with hot glue and wedges to support.

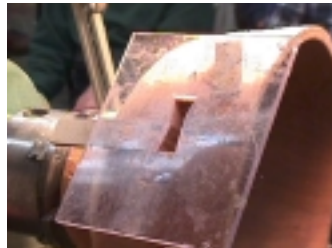

Rout bow tie cutout with straight or spiral bit and collar. Clean up corners and glue in contrasting bow tie.



2004 MSSW Officers

President - Hank Cahill (781) 878-0234

Vice President - Felix Troiano (781) 749-1713

Treasurer - Wally Kemp (781) 871-1390

Secretary - Mal Partridge (781) 843-3883

Librarian - Leonard Mandeville (508-586-7679)

Newsletter - Mal Partridge (781) 843-3883

Web site: <http://www.mssw.sitelinker.org/>



Next Meeting

Tuesday, May 25, 2004, 7:00 P.M.

At Hank Cahill's *Dust Bowl*

Refreshments by: John Murphy

Member Challenge: Off center bowl

using 2 centers + decorations

Demonstration: Sharpening by Peter Teubel

Meeting Minutes

The meeting was called to order at 7:00 pm at Hank Cahill's Dust Bowl

President's Report and General Business

Hank introduced guest Nigel Howe. He showed a newsletter from Surrey Woodturners which contained a description of spindle terms. (Editors note: We had a similar Spindleology in our November 2002 Newsletter. A spindle sampler was the Member Challenge.)

Our booth/demonstration at the South Shore Art Center Show at Cohasset June 18, 19, & 20 will be manned by John Murphy, Richard Friberg, Sidney Katz, David Hutchins and other volunteers TBD.

Two other upcoming shows are: Soule Homestead Educational Center, Middleboro, September 18-19, and Onset Creative Arts Association, August 21, 9-3.

Hank received an E-Mail from AAW Liaison John Hill, a board member, about getting involved on standing committees. He also wants members who have not joined AAW to do so and sent membership forms.

A visit to Old Schwab Mill will be set up for a Saturday in June for interested members.

Mal submitted newsletter expenses to Wally for 5 months in the amount of \$203.65.

LaymarCrafts in the U.K. has a great woodturning web site with over 2600 links to woodturning sites:

<http://www.laymar-crafts.co.uk/index.htm>

Under Hints & Tips - #67 Chainsaw Sawing Platform/log cradle is interesting. A printout was made available for members to view.

Our Gnome engine was on display at the MIT Museum Festival of Flight, April 25.

Treasurer Wally Kemp reported \$2420 in treasury. For the year 2003:

| | |
|----------------|-----------------------|
| Income: \$1659 | Expenses: \$1504 |
| Dues \$800 | Printing & Mail \$500 |
| Raffle 221 | Demos 550 |
| AAW 500 | Video 135 |
| Video 138 | Misc. 319 |

More Show & Tell

By Emilio



Egg timer - 2 centers

Tilted box

Duck from Mike Darlow's book



Oval shape maple tool handle



Scoop and handle all one piece

Taking a bite of the apple. The stem that looks so real, is.



Lenny the Librarian reported 2 dozen new books were received. We now have a total of 55 books and 57 videos. Only a few are checked out at this time. New members should take advantage of this resource.

Jeff and Wally will be demonstrating at the Norwell Library Saturday, June 12th, setup at 10, and the demo 11-1. They will have two lathes and display/sales table.

Richard and Janet gave a 1 1/2 hour demo on turning ballisters and carving at the Restoration show at the Hynes Center. Examples were shown at our show & tell.

John Murphy reported on the long range plans for the Fuller Crafts Museum exhibits which are booked thru 2006. He will continue to see if we can have a display of woodturnings, perhaps a New England group.

Self winding
Top

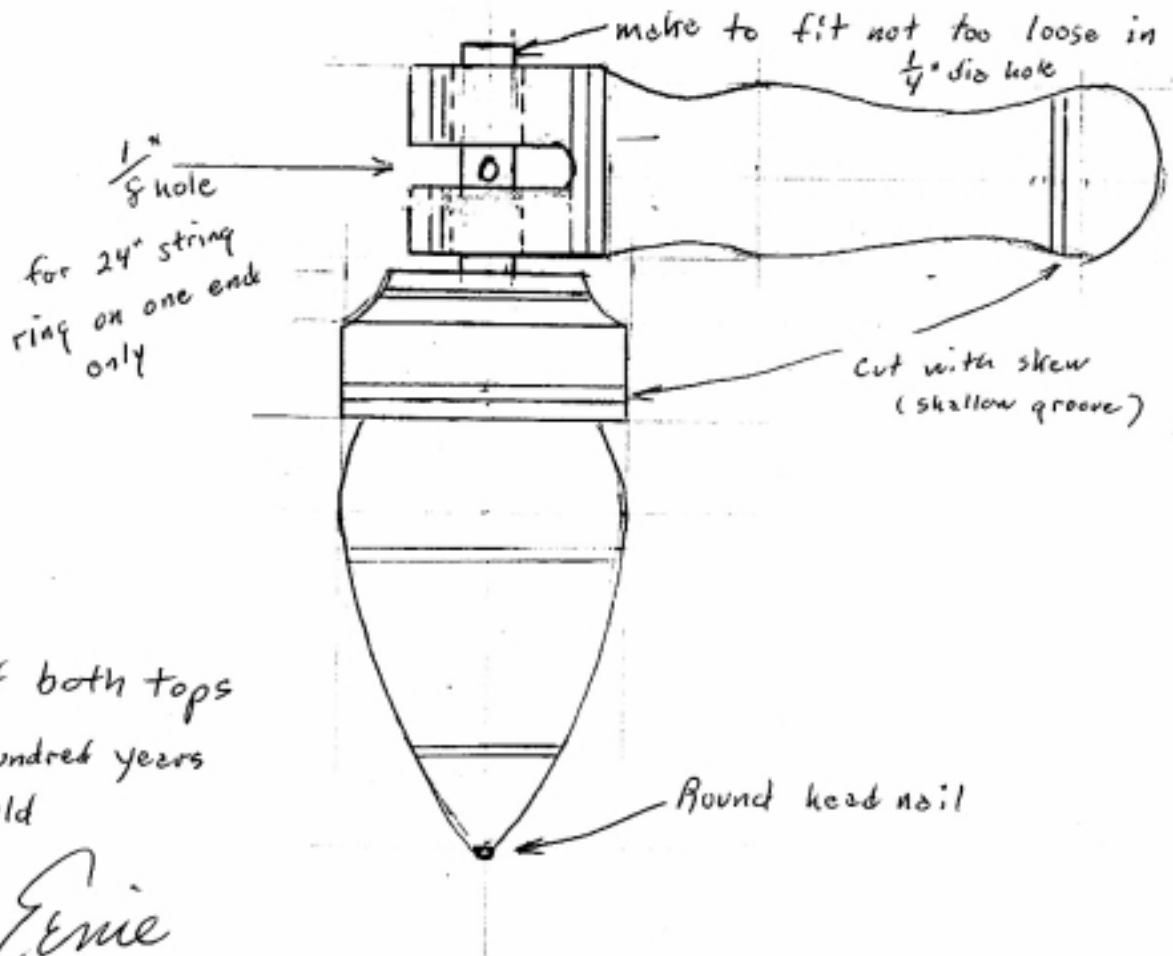
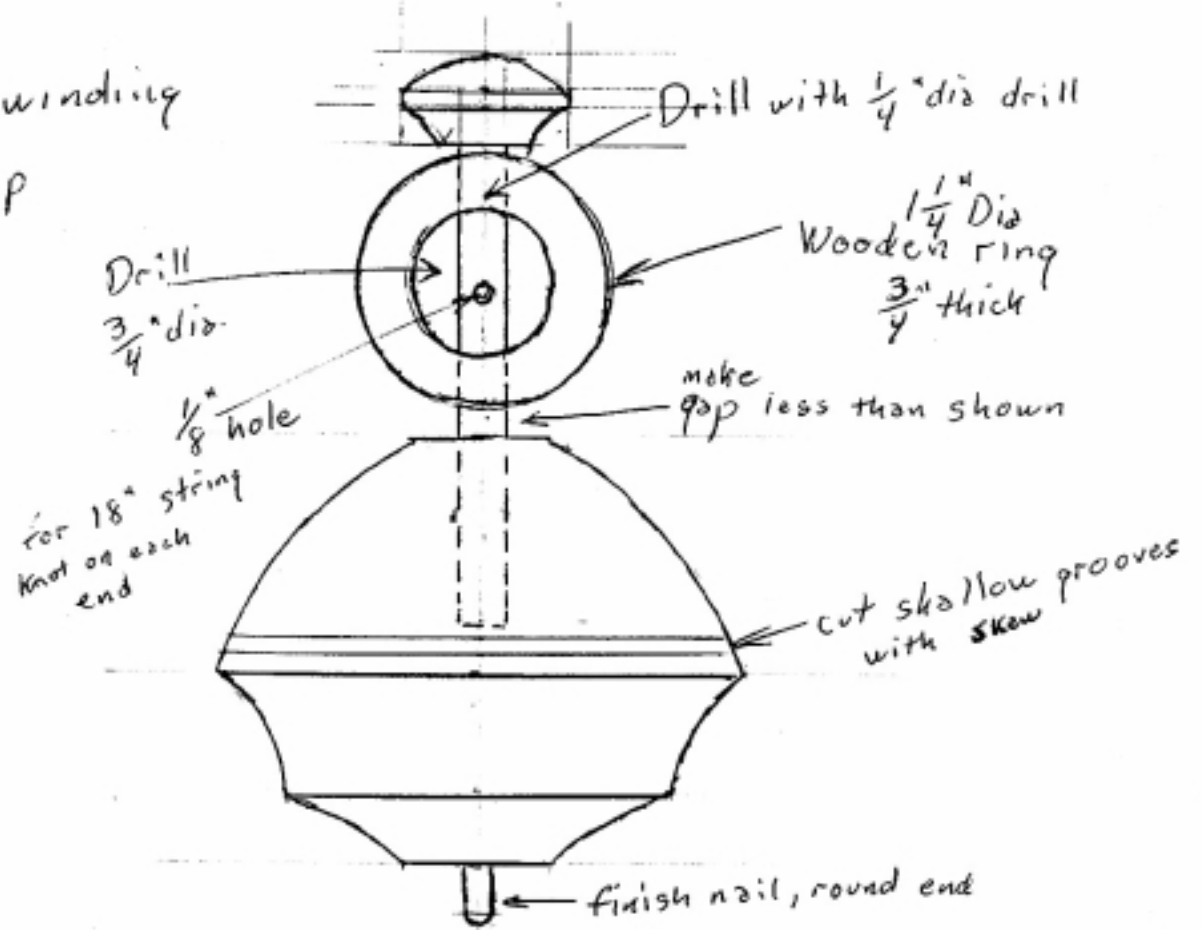

Design of both tops
several hundred years
old

Ernie

Show & Tell

April 2004



Richard's carved medallion & two vases



Jeff's two bowls and basswood ladles



Don's cedar bowl in process



Sidney's candle sticks, sugar maple & ash bowls



Wally's pedestal bowl



Lenny's bird house



Andy's bowl from Angelo's burl, bowl from limb & cherry bowl, sprayed lacquer finish

Graeme Young's oval bowl



Jean's natural edge bowl, fish lips carving on burl & white painted and textured bowl



Jim's cedar bowl & birch pedestal bowl



Hank's two spalted maple wall hanging plates



Peter's spalted maple bowl & oak burl/box elder vase Harold's outstanding segmented pieces